

# CB04

## PUCK LIGHT

### SPEC SHEET

HEAVY DUTY  
CAST ALUMINUM

10W AC/DC  
12V LED



900 LUMENS

AVAILABLE FINISH:



BRUSHED NICKEL



BLACK



WHITE

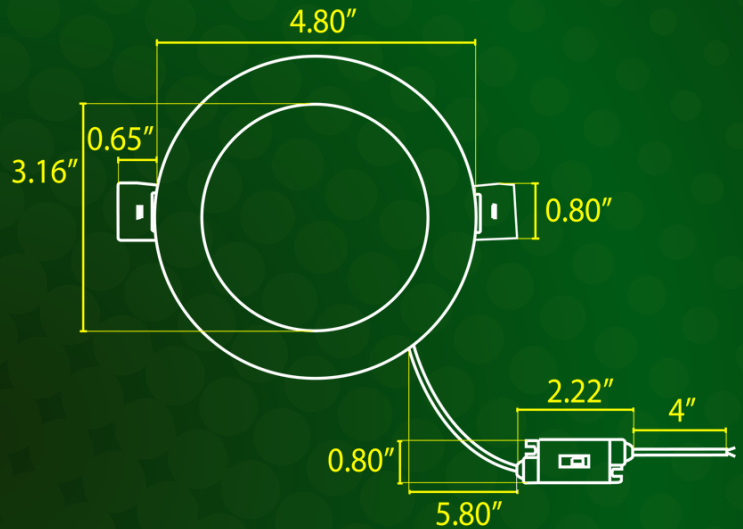
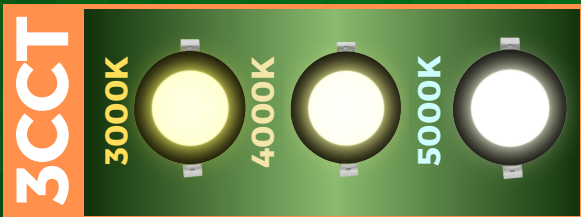

INTRODUCING THE CB04-3CCT LED DRIVER PUCK LIGHT BY ABBA LIGHTING USA—A VERSATILE AND EFFICIENT LIGHTING SOLUTION DESIGNED TO SEAMLESSLY INTEGRATE INTO VARIOUS INTERIOR SPACES. THIS SLIM ROUND PANEL LIGHT COMBINES MODERN AESTHETICS WITH ADVANCED FUNCTIONALITY, MAKING IT AN IDEAL CHOICE FOR BOTH RESIDENTIAL AND COMMERCIAL APPLICATIONS.

PERFECT FOR ILLUMINATING RESIDENTIAL SPACES SUCH AS KITCHENS, HALLWAYS, AND LIVING AREAS, PROVIDING ADJUSTABLE LIGHTING TO MATCH DIFFERENT MOODS AND ACTIVITIES. IN COMMERCIAL SETTINGS, IT SERVES AS AN EFFICIENT LIGHTING SOLUTION FOR OFFICES, RETAIL STORES, AND HOSPITALITY VENUES, OFFERING FLEXIBILITY IN COLOR TEMPERATURE TO CREATE THE DESIRED ATMOSPHERE.



YOUTUBE VIDEO  
INSTALLATION GUIDE



WEBSITE



CATALOG



12V Landscape Light Specialist



(800) 360-2960



ABBALightingUSA@gmail.com



7701 Alabama Ave, Canoga Park, CA 91304